

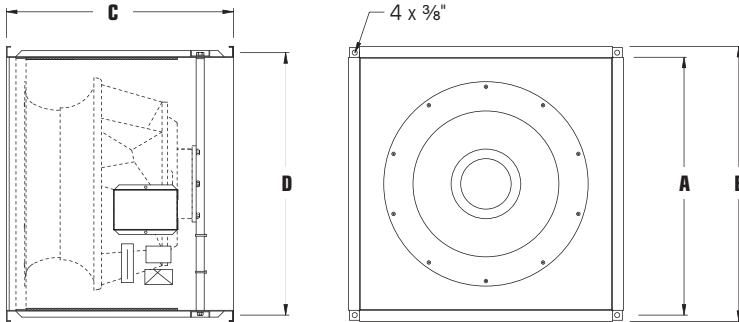

SUBMITTAL DATA

FSD SERIES Inline Centrifugal Fans



STANDARD FEATURES

- Galvanized steel housing with baked powder coat finish
- Powered by external rotor motorized mixed flow impeller
- Permanently lubricated sealed ball bearings
- 100% speed controllable
- Automatic reset thermal overload protection
- Prewired electrical box
- Three-year factory warranty

Model	A	B	C	D	Metal Gauge	Avg Wt. (lbs)
FSD 18	17 5/8	19 3/8	15 3/4	18 1/2	16	55
FSD 20	19 3/4	21 1/2	17 3/4	20 5/8	16	65
FSD 22	21 1/2	23 3/8	19	22 1/2	16	95
FSD 26	26	27 3/4	20	26 7/8	16	135

All dimensions in inches.

Fan Specifications							Motor Specifications				
Line	Qty	Model No.	Tag	CFM	SP	Fan RPM	Watts	Volts	Phase	Hertz	Encl
1											
2											
3											
4											
5											

Accessory Items	1	2	3	4	5	Accessory Items	1	2	3	4	5
<input type="checkbox"/>						<input type="checkbox"/>					
<input type="checkbox"/>						<input type="checkbox"/>					
<input type="checkbox"/>						<input type="checkbox"/>					
<input type="checkbox"/>						<input type="checkbox"/>					
<input type="checkbox"/>						<input type="checkbox"/>					

Project: _____ Submitted: _____
 Customer: _____ Approved: _____
 Location: _____

